

Shanghai, China (Headquarters)  
Huizhou, China (Production base)

Shenzhen, China (Sales Center)  
Sydney, Australia (Sales Center)

# TCSN POWER

## Merak50-161kWh-SP



Huizhou Tianchen Shangneng Technology Co.,Ltd  
No. 3 Building,Wuyi village Road,Chenjiang Street,Zhongkai  
High-Tech Zone,Huizhou City,Guangdong,China

TCSN Power Technology (Shenzhen) Co., Ltd  
1701-2 Qianhai Xiangbin Building,No.18,West Free Trade  
Street,Nanshan Street,Qianhai Shenzhen-Hong Kong Cooperation  
Zone,Shenzhen

Tel: +86 752-3329629

Email: [info@tcsnpower.com](mailto:info@tcsnpower.com)



HUIZHOU TIANCHEN SHANGNENG TECHNOLOGY Co., Ltd

# 1 Introduction

The air-cooled energy storage battery system has a capacity of 161kWh, and the battery system includes battery PACK, Air-cooled, BMS and fire protection system. The entire system is connected to 380V AC.



Figure 1-1 Schematic diagram of the battery cabinet

Table 1-1 Battery cabinet parameter table

Id	Category	Technical parameters
1	Cell type	3.2V/280Ah, LFP
2	Rated energy of the system	161kWh
3	Battery grouping method	3*1P60S
4	System voltage	450~648V
5	Chargedischarge rate	≤0.5P
6	Battery efficiency	≥ 94% (excluding AC auxiliary power).
7	Operating temperature range	Discharge:-20~55°C; Charging: 0~55°C
8	Fire fighting methods	Aerosol firefighting
9	Methods of Communication	CAN、RS485、ModbusTCP、LAN
10	Cooling method	Air-cooling
11	Ingress protection	IP54
12	Corrosion protection level	C3
13	weight	2.1t
14	Size (W*D*H)	1000*1450*2100 mm (without lifting rings).
15	Humidity range	0~95%(no condensation).
16	Maximum working altitude	5000m (>3000m derating)
17	Authentication	GB_T 36276-2023, UN38.3, IEC62619

## 2 System Configuration

### 2.1 Battery Park



Figure 2-1 PACK Appearance Diagram

Table 2-1 Battery Box Parameter Table

1	Cell type	LFP
2	Charging rate	≤ 0.5P
3	discharge rate	≤ 0.5P
4	Composition	1P60S
5	Nominal capacity	280Ah
6	Nominal energy	53760Wh
7	Nominal voltage	192V
8	Operating voltage range	150~216V
9	Voltage harvesting	Full collection + total positive/total negative
10	Temperature collection	High precision, stable and anti-interference
11	Maximum operating temperature range	Charging 0°C~55°C; Discharge -30°C~55°C
12	Optimal operating temperature	25°C±2°C;
13	Transport & Storage Temperature (Battery 30% SOC).	-20°C~45°C within one month; -20°C~25°C within 6 months
14	Insulation properties	Resistance ≥ 500MΩ@2500VDC

15	Withstand voltage	Leakage current ≤ 1mA @4500VDC, no spark and no breakdown
16	IP rating	≥ IP67
17	Ambient humidity	< 90% RH (non-condensing)
18	Cooling method	Air-cooled
19	Product weight	360kg
20	Dimensions (W*D*.H)High.	750±2mm×1240±2mm×282±2mm

### 2.2 Battery Rack Specifications

Rated Voltage(V)	576	<b>【3modules series】</b>
Series & Parallels	1P180S	
Rated Capacity(Ah)	280	
Voltage range(V)	450~648	
Continuous charge/discharge current(A)	140/140	
Rated Energy(kWh)	161	3modules series, singlecluster
Discharge cut-off voltage(V)	450	
Charge voltage(V)	648	
Cycle life (@25°C, 0.5C/0.5C,80%DOD)	> 6000	25±2°C, 0.5C/0.5C, 70%SOH
BatteryThermal Management	Air cooling	
Operating temperature	-20~55°C	
Operating humidity	5%~95%R.H.	
Communication	CAN/RS485	

## 2.3 Battery Management System

ESMU Technical Parameters	
Project	Parameters
Central Processing Unit	ARM platform, quad - core, with a maximum main frequency of 2.0GHz
Memory	4GB LPDDR4
Operating System	Linux
SD Card Storage	16GB eMMC 240G - 500G SSD 32G SD card (optional)
Number of Detectable Batteries	Up to 450 cells × 60 clusters
Liquid Crystal Screen	10.1 - inch true - color touch - screen LCD
Data Recording Interval	≥1S (configurable)
Query Methods	On - site panel query, remote access query, data export/download
Alarm Methods	Acoustic - optical alarm, display alarm content, fault output node closure
Communication Interfaces	3 - way LAN, 3 - way isolated CAN, 5 - way isolated RS485, 2 - way USB

DO/DI Interfaces	6 - way DIH IO input with photoelectric isolation 6 - way DIL IO input with electrical isolation 12 - way IO output with relay dry - contact mode 1 - way AC power - failure detection
Remote	Supports MQTT protocol; supports Modbus TCP, IEC61850 protocols
Event Log Database	>100000 event records, including anomaly types, occurrence times, and protection actions, supporting full - life - cycle data storage
ESMU Power Supply	DC24V
ESMU Power Consumption	<10W (initial state with screen on)
Communication Baud Rates	9600bps @ RS485, 250Kbps @ CAN, 100Mbps/1000Mbps @ LAN
Dimensions/Mass	288×190×41.2mm / 1.8kg
Material	Sheet metal
Process	Three - proof paint
Insulation Resistance	500MΩ 1500VDC
Operating Environment	Ambient temperature: -10 - +55°C, relative humidity: <95% (non - condensing), ambient magnetic field: <400A/m, no corrosive or flammable and explosive gases allowed in the surroundings

The energy storage system is equipped with a complete battery management system, adopts a three-level management architecture and three-level software protection, including module level, battery cluster level and system level, to achieve comprehensive control, management and protection of the battery system and ensure the safe and stable operation of the battery system.

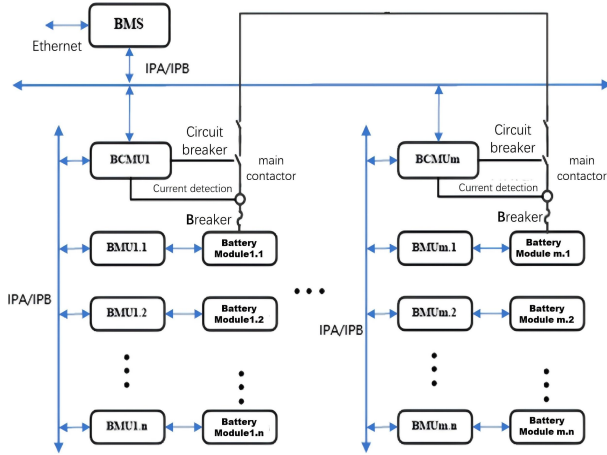

## 2.4 High voltage box



Table 2-2 Technical parameters of high-pressure box

ID	Name	Technical parameters
1	Current rating	250A
2	Operating voltage	1000V
3	SOC accuracy	5%

## 2.5 Inverter(50kW)



### Electrical Connection

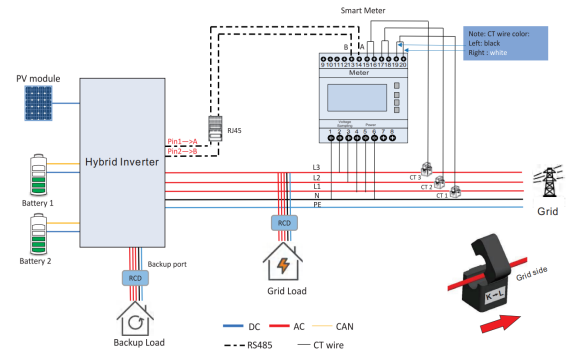

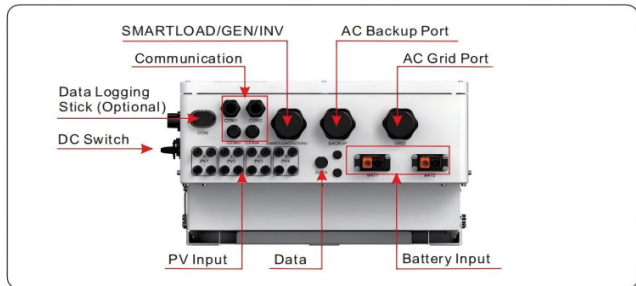

Figure 2-3 Schematic diagram of a Air-cooled unit

Table 2-3 Technical parameters of Air-cooled unit

Name	Description
1. DC Switch	This is the DC disconnect switch for the PV
2. COM	Soils data logger gets connected here-only USB version of the loggers will work
3. COM1	RS485 and CAN communication cables and parallel cables should go through these
4. COM2	RS485 and CAN communication cables and parallel cables should go through these
5. COM3	Communication cables for 14PIN terminal block should go through these
6. COM4	Communication cables for 14PIN terminal block should go through these
7. SMARTLOAD/GEN/INV	Conduit for AC conductors to generator should be connected here
8. Backup	Conduit for AC conductors to backup loads panel should be connected here
9. Grid	Conduit for AC conductors to the main service panel should be connected here
10. PV Module Input	Conduit for PV conductors should be connected here
11. Battery Connection	Conduit for Battery conductors should be connected here
12. DATA	Extends the range of the inverter GPRS signal(Not applicable to the USA,Australia,Europe)
13. ON/OFF	This button is on machine left side,used for inverter power on/off

## 2.6 Thermal management system

The EIB series outdoor cabinet air conditioner is a cooling product developed for cabinet. It is applicable for the scenarios where internal equipment of the cabinet emits a large quantity of heat and the internal equipment is sensitive for temperature and needs to be isolated from the outdoor environment completely. The unit has perfect functions, such as with external fan controlled functions and features high reliability and easy installation, so that it can work once the power supply is available and no complex adjustment is needed.

The internal cycle air path absorbs the hot air from the upside, and discharges the cold air from the downside of the air conditioner. The external cycle air path absorbs the external cold air from the downside, and discharges the hot air from the upside after heat exchange, as shown in Fig.1.1.

Note: It is prohibited to put the air conditioner upside down during transportation, storage and use.

Type	Pin	definition
Power input	L1/L	L:220VAC power input cable L; L1:110VAC power input cable L
	L2/N	N:220VAC power input cable N; L2:110VAC power input cable L
	PE	Grounding wire of the air conditioner
Alarm output	NC	The first public alarm dry nod (NC)
	COM	The first public alarm dry nod (COM)
	NO	The first public alarm dry nod (NO) (Option)
	1	The second public alarm dry nod (COM) (Option)
Signal input	2	The second public alarm dry nod (NO) (Option)
	3	N/A
	4	Hydrogen discharge / emergency fan dry contact (FG) (Option)
	5	Hydrogen discharge / emergency fan dry contact (NO) (Option)
	6	Hydrogen discharge / emergency fan dry contact (COM) (Option)
	7	
	8	Door open alarm input (Option)
	communication ports	+
-		RS485 communication ports (-) (Option)

## 2.7 Fire protection system

This product divides the energy storage system into multiple levels for protection.

PACK level: early detection and rapid extinguishing of root fire sources;

Cluster level: Focus on controlling external fire sources, preventing their spread, and suppressing their growth.

附:产品外形尺寸图(单位: mm)

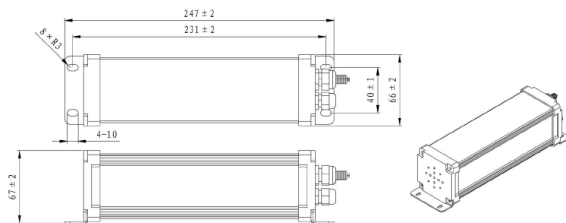

Figure 2-4 Schematic diagram of the fire extinguishing device

Table 2-4 Technical parameters of fire protection system

ID	Project	Performance/Parameters
1	Filling media	aerosol
2	The quality of the filling agent	5*40g(PACK level)+1*300g(cluster level).
3	Supply voltage	24V
4	Methods of Communication	CAN communication/485 communication
5	Protect the space	5m <sup>3</sup>
6	expiration date	10 years

## 3 Precautions

### 3.1 Safety Precautions

- It must be operated by a professional electrical personnel or a trained technician.
- Make sure the high-voltage power switch is disconnected when installing.
- Please carefully inspect the materials before installation, if there is any missing or damaged, please do not install dangerously.
- Insulating gloves must be worn during installation, and the outside of the metal tool must be tightly wrapped with insulating tape before use.
- During installation, it is strictly forbidden to contact the total positive and total negative of the battery pack at the same time, so as not to hurt people with high voltage.
- Non-professionals are forbidden to disassemble the module shell, let alone touch the internal circuit board, so as not to cause electric shock accidents.
- Without the confirmation of the manufacturer's technical personnel, it is forbidden to modify or use this system on other projects to avoid serious accidents.

### 3.2 Guidelines for safe use

- Safeguard measures should be provided for the safe and reliable operating environment of the battery system.
- The power should not be greater than the rated power when in use, and the system should be kept away from fire, heat and water sources in use, if the battery leaks or emits peculiar smell, it should be stopped immediately, and the relevant personnel should be notified in time to deal with it.
- The battery system is fully charged and fully discharged every six months, and the recommended charge and discharge rate is 0.5C, and detailed records are made.
- Before the energy storage battery is stored for a long time and operated, the battery system must be inspected for safety to avoid equipment damage or system safety problems caused by loose connections, water vapor condensation, rust or mold.